



# ENERGY PLUG

Decentralized Energy Technologies

Q4.2024



## Forward-Looking Statements

This presentation contains forward-looking statements and information that relate to Energy Plug Technologies Corp. (together with its affiliates, "**Energy Plug**" or the "**Company**"). Statements which are not purely historical are forward-looking statements and include any statements regarding beliefs, plans, outlook, expectations or intentions regarding the future including words or phrases such as "anticipate," "objective," "may," "will," "might," "should," "could," "can," "intend," "expect," "believe," "estimate," "predict," "potential," "plan," "is designed to," "project," "continue" or similar expressions suggest future outcomes or the negative thereof or similar variations. Forward-looking statements may include, among other things, statements about: our business strategy; our strategic partnerships, including the proposed partnership with the Malahat Nation; estimate of potential earnings; the construction and operation of a gigafactory with Malahat Nation; regulatory approvals; our expectations regarding our expenses, sales and operations; our future customer concentration; our anticipated cash needs; estimates regarding our capital requirements; our need for additional financing; our ability to anticipate the future needs of our customers; our plans for future products; our future growth strategy and growth rate; protection of our intellectual property; and anticipated trends and challenges in the markets in which we operate. The forward-looking statements have been prepared by our management to provide an outlook of our activities and results and may not be appropriate for other purposes. Our management believes that the forward-looking statements have been prepared on a reasonable basis, reflecting management's best estimates and judgments. An investor should read this presentation with the understanding that our actual future results may be materially different from what we expect. Such statements and information are based on numerous assumptions regarding present and future business strategies and the environment in which Energy Plug will operate in the future. Although Energy Plug believes that the assumptions underlying these statements are reasonable, they may prove to be incorrect. Given these risks, uncertainties and assumptions, you should not place undue reliance on these forward-looking statements. The securities of Energy Plug are considered highly speculative due to the nature of Energy Plug's business.

Forward-looking statements are subject to known and unknown risks, uncertainties and other important factors that may cause the actual results to be materially different from those expressed or implied by such forward-looking statements, including but not limited to, business, economic and capital market conditions; our limited business history; risks related to our corporate strategy including that previous and future acquisitions do not meet expectations; the ability to manage our operating expenses, which may adversely affect our financial condition; our ability to remain competitive as other better financed competitors develop and release competitive products; regulatory uncertainties; market conditions and the demand and pricing for our products; security threats; our relationships with our customers, distributors and business partners; our ability to successfully define, design and release new products in a timely manner that meet our customers' needs; failure to retain and/or recruit customers; our ability to attract, retain and motivate qualified personnel; competition in our industry; our ability to maintain technological leadership; the impact of technology changes on our products and industry; our failure to develop new and innovative products; our ability to successfully maintain and enforce our intellectual property rights and defend third-party claims of infringement of their intellectual property rights; the impact of intellectual property litigation that could materially and adversely affect our business; our ability to manage working capital; our dependence on key personnel; our supply chain management; availability of suppliers of materials for our products; and failure to expand production capacity. Important factors that could cause actual results to differ materially from Energy Plug's expectations include litigation, global economic climate, equipment failures, increase in operating costs, security threats, consumer interest and sentiment in Energy Plug's products, government regulations, loss of key employees and consultants, additional funding requirements, changes in laws, technology failures, competition, and failure of counterparties to perform their contractual obligations. Energy Plug's products have yet to be produced at scale.

Except as required by law, we undertake no obligation to update or revise any forward-looking statements, whether as a result of new information, future event or otherwise, after the date on which the statements are made or to reflect the occurrence of unanticipated events. Neither we nor any of our representatives make any representation or warranty, express or implied, as to the accuracy, sufficiency or completeness of the information in this presentation. Neither we nor any of our representatives shall have any liability whatsoever, under contract, tort, trust or otherwise, to you or any person resulting from the use of the information in this presentation by you or any of your representatives or for omissions from the information in this presentation. This presentation is for information purposes only and may not be reproduced or distributed to any other person or published, in whole or part, for any purpose whatsoever. This presentation does not constitute a general advertisement or general solicitation or an offer to sell or a solicitation to buy any securities in any jurisdiction. This presentation and materials or fact of their distribution or communication shall not form the basis of, or be relied on in connection with any contract, commitment or investment decision whatsoever in relation thereto. No securities commission or similar authority in Canada or any other jurisdiction has in any way passed upon the adequacy or accuracy of the information contained herein.

The information contained herein includes market and industry data that has been obtained from third party sources, including industry publications. Energy Plug believes that its industry data is accurate and that its estimates and assumptions are reasonable, but there is no assurance as to the accuracy or completeness of this data. Third party sources generally state that the information contained therein has been obtained from sources believed to be reliable, but there is no assurance as to the accuracy or completeness of included information. Although the data is believed to be reliable, the Energy Plug has not independently verified any of the data from third party sources referred to in this presentation or ascertained the underlying economic assumptions relied upon by such sources.

Energy Plug owns or has rights to various trademarks, service marks and trade names that it uses in connection with the operation of its business. This presentation may also contain trademarks, service marks and trade names of third parties, which are the property of their respective owners. The use or display of third parties' trademarks, service marks, trade names or products in this presentation is not intended to, and does not imply, a relationship with Energy Plug, or an endorsement or sponsorship by or of Energy Plug.

- Global Power outages market **\$473 billion** An.
- Global Energy Management market **\$112 billion** An.

## 2030

- **\$4.1 trillion** for maintaining existing electricity grids
- **\$17.3 trillion** for expanding grids to meet demand
- **\$3.1 trillion** needed for grid infrastructure upgrades

<https://about.bnef.com/blog/global-net-zero-will-require-21-trillion-investment-in-power-grids/>  
<https://www.fortunebusinessinsights.com/industry-reports/energy-management-system-market-101167>

# Power Outages

*Affecting sectors such as manufacturing, services, transportation, IT services, agriculture, & mining*





# Market Gap

Commercial & Industrial Market  
20 kWh - 500 kWh



Residential 5- 13.5 kWh



Grid Scale - 5 MWh +



Pad & Pole Mounted Battery Systems





# Market Solution

Powering Homes, Businesses, and Utility-Scale Applications



## 20 kWh Energy Pack

*Reimagined power solution*

### Interoperable Design

Standardized air cooled components across products simplifies inventories, maintenance, and increases uptime.

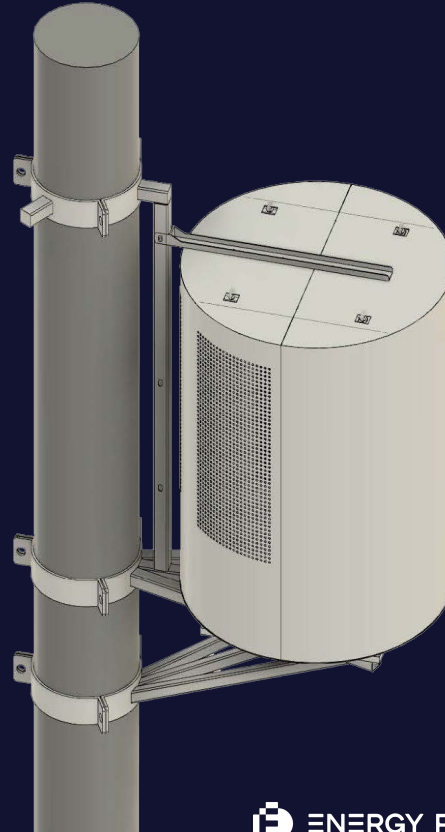

## 20 kWh Energy Pole

*Re-thinking energy infrastructure*

### Modular

Common battery modules, inverters and EMS allow for easy expansion and broader system coordination from residential to utility-scale networks.

### Certifications

- UL 1973 - Safety standard for battery energy storage systems
- UL 60730 - Standard for Automatic Electrical Control
- UL 916 - Standard for Energy Management Equipment
- UL 62619 - Standard for lithium-ion batteries.
- UL 9540 Pending - Standard for Energy Storage Systems

Proudly Canadian





# 20 kWh Energy Pack

*A reimagined simple power solution*

## Features

**20 kWh Capacity:** Ideal for plug and play backup power, peak shaving, improved power quality, and energy arbitrage.

**Integrated PCS:** Built-in bi-directional inverter for seamless grid and renewable energy management.

**Automatic Backup:** Ensures uninterrupted power during outages, and generator downtime, perfect for critical loads.

**Solar-Ready:** Easily integrates with solar PV systems for enhanced energy independence and reduced charging costs.

**Remote Monitoring:** Customizable EMS for real-time control and optimization via dashboard.

**Durable:** Robust, weather-resistant design for reliable outdoor use.

Proudly Canadian





# 20 kWh Energy Pole

Energy Plug *Re-thinks* storage and infrastructure with batteries

## Features

**Arbitrage:** Utilities can proactively balance their power supply and demand curves.

**Load-Leveling & Peak-Shaving:** Smooths out energy usage, reducing strain on the grid and cutting peak energy costs.

**Grid Stability:** Responding to grid fluctuations improves power quality and reduces outages by absorbing demand spikes.

**Durable:** IP 65, -40 to +55 degrees Celsius

**Efficient:** Reduces infrastructure costs to improve power quality for Rural & Remote communities



<b>Battery Type</b>	<b>LiFePO4</b> – Long-lasting, safe, and environmentally friendly.
<b>Cycles</b>	<b>6,000 - 8,000 cycles</b> – Supports daily charge and discharge, providing reliable performance for 16 to 22 years under normal conditions (at 90% Depth of Discharge).
<b>Output Power</b>	<b>10 kWh continuous</b> – Supports critical systems and steady energy supply.
<b>Output Voltage</b>	<b>240VAC</b> – Suitable for distribution and commercial applications.
<b>Size</b>	<b>1205mm (h) x 900mm (d)</b> – Similar in size to a typical pole-mounted transformer, offering compact, space-efficient installation.
<b>Weight</b>	<b>240 kg</b> – About one-third the weight of a typical pole-mounted transformer, allowing easier installation with standard equipment.

Proudly Canadian







# Blue Ocean - Decentralized Utility Energy as a Service Business Model

## EaaS Model Highlights:

### 1. Subscription Fees:

Affordable access without upfront costs.

### 2. Energy Savings Sharing:

Revenue via efficiency gains and blackout prevention.

### 3. Peak Shaving/Demand Response:

Supporting grid stability with cost-sharing incentives.

- **Lower Energy Costs:** Peak shaving, demand response, and energy efficiency reduce utility bills and earn incentives.
- **Blackout Savings Sharing:** Avoid costly downtime with shared savings on blackout prevention.
- **No Upfront Costs:** Subscription-based access eliminates capital expenses while delivering long-term savings.





# Blue Ocean - Decentralized Nodes Cryptocurrency Business Model

## Decentralized Energy Nodes

Peer-to-peer energy trading, reducing reliance on centralized grids and enhancing resilience.

**Real-Time Trading:** Enables secure energy transactions, creating revenue streams by monetizing surplus energy and managing fluctuating needs.

**Enhanced Connectivity:** Supports base stations, satellites, AI, and blockchain nodes, ensuring reliable energy for critical infrastructure.





# Milestones & Road Map

Where we've been and where we're going

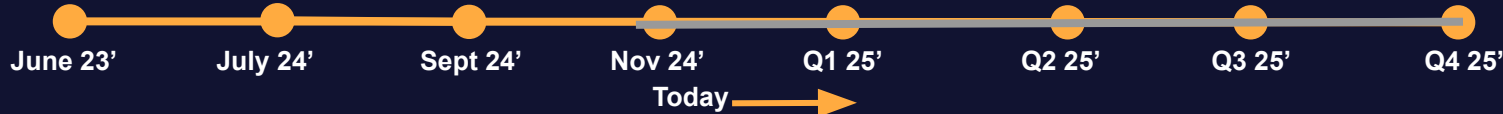
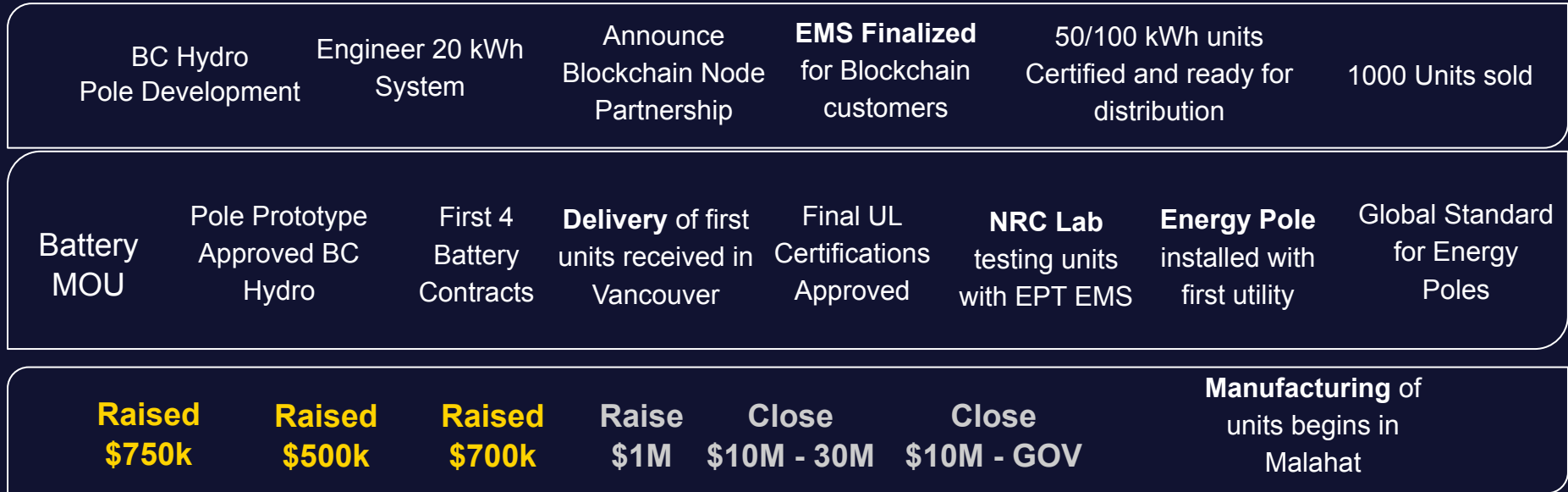

CSE: PLUG OTCQB: PLGGF FSE: 6GQ

# Partnership Matrix



## Energy Management



*Scaling energy savings business model  
w/ agnostic EMS Battery & DER integrations*

## Battery Solutions



*Pairing long duration and LFP chemistry  
together to provide a robust global market solution*



*Indigenous Power Opportunities, Data Centres, & PPP*



*Adding long duration storage to EPT manufacturing plans  
Group synergies to fast track strategic market SKD assembly*

## Energy Programs

## Manufacturing

# Indigenous Manufacturing Partnership

Clean Energy and Grid Stability

Targeting 1 GWh of annual production - Q4 2025

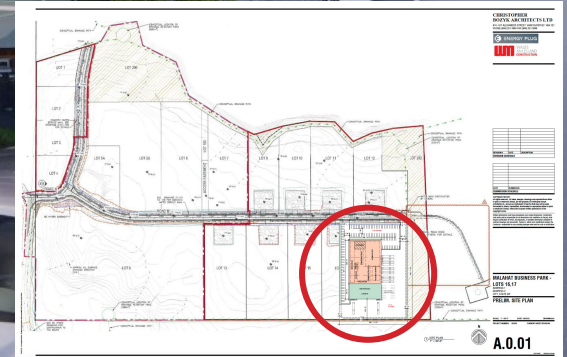



# Milestones

Our Path to Innovation and Growth

<b>Grid Scale 5 MWh</b>	MOU Seetel	Sales Pipeline \$700M+	Grid Scale Planning	Commercial Contracts Cells & Offtake Partners	Manufacturing of 5 MWh unit begins			
<b>Commercial 20 kWh</b>	Design of prototype model finalized	Delivery of first units received in Vancouver	EMS Finalized for Commercial customers	Manufacturing of commercial units begins in Malahat				
<b>Utility 20 kWh</b>	BC Hydro Product Developed	Design of prototype model finalized	NRC Lab testing units with EMS	Canada NRC-CNRC	Manufacturing of the 20 kWh units begins in Malahat			
<b>BC Hydro</b>	MOU Siemens Canada	<b>SIEMENS</b>	<b>FNFA</b>	First Product Installations	Energy Pole First utility			
<b>Partnership Malahat Nation &amp; EPT</b>	GP/LP Established Malahat Nation & EPT	Ground Blessing Construction begins	FNFA \$24M Loan Approval	Financing Strategic Partners Join	Long Lead Capital Expenditures	Construction Building Shell Completed	Manufacturing Initial Production line build out	Production Training, First Production runs

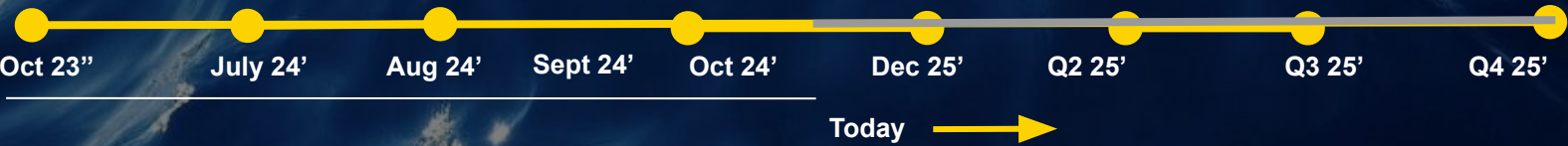



# Ground Breaking Ceremony

Gigafactory Ground Blessing - August 28, 2024



As featured in...

**Global NEWS**

**ELECTRIC AUTONOMY**  
CANADA

**VANCOUVER SUN**

**NationTalk**

**pv magazine**

**TIMES**

**COLONIST**

**Energy Storage NEWS**

**THE GLOBE AND MAIL**





# Customer Pipeline

Early Product Traction While we Prepare for Mass Production

## \$206M

## Total Sales Pipeline

@ October 31, 2024

**Small Scale**  
**20 kWh - 100 kWh**

\$4.08M



**Utility Scale**  
**20 kWh - 100 kWh**

\$1.59M

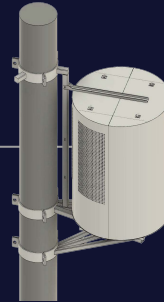

**Grid Scale**  
**1 MWh +**

\$200.2M





# IP, Supply Chain & Partnerships

*Leading the Charge in BESS Manufacturing and System Integration*

## INTELLECTUAL PROPERTY

- Exclusive License Energy Pack
- Exclusive License Energy Pole
- Exclusive License Data Centres
- Exclusive license of Energy Management Syst.
- Exclusive license of Power Management Syst.

## SUPPLY CHAIN

- Enwind Power — Design and engineering partner in Taiwan
- Co-developed battery standard, UL 1974
  - Certified technology now in use globally
  - Data Centre compliant batteries
  - Reliable on-time manufacturing
  - Trusted by global brands
  - Enwind Power and Energy Plug untied in IP partnership
  - Manufacturing until Canadian factory opens



## PARTNERSHIPS

- Malahat Nation, world's first indigenous-led battery Gigafactory
- Siemens Canada - Technology Partner
- Johnson Controls - System Integration Partner
- BC Hydro - Joint developer Energy Pole for utilities
- Hydro One - Approved Battery Vendor
- Enwind Power - Global leader in UL Batteries
- Ximen Mining 20 kWh Battery Generator program for, reducing GHGs, operational costs and black-out resiliency
- Power Touch Data Centres, utilization of excess power in Energy Plug Batteries for ASUS AI global server network
- Elastic Energy - Battery Pack Partnership for 10 kWh Residential Batteries



# Leadership Team

Manufacturing, Batteries, Energy



**Broderick Gunning**

*Chief Executive Officer  
Board*

A seasoned leader in fintech and energy sectors, with expertise in fintech, EV infrastructure, and finance. Experienced in large-scale projects across North America and Asia, focusing on trust and growth.



**Ramtin Rasoulinezhad**

*Chief Technology  
Officer*

A seasoned executive in the energy sector, specializing in clean technologies, renewable energy, and energy storage. He excels in leading technology projects, decarbonization initiatives, and building high-performing teams.



**Chris Barnes**

*VP Ops*

Over 15 years of experience in renewable energy and technology, Chris has led large-scale operations and innovative wind and solar projects totalling nearly 400MW ac.



**Jonathon Redbird**

*Board - Indigenous  
Partnerships*

Over two decades of corporate and entrepreneurial experience, primarily working for First Nation Governments and Leaders of Corporate Canada



**Tony Kuo**

*Asia Partnerships*

A Taiwanese-born, North American-raised investment banker specializing in technology and energy sectors across Asia. Fluent in English, Mandarin, and Cantonese, focusing on Asia-Americas, in growth-stage ventures.



**Connie Hang** CPA, CGA

*Chief Financial Officer*

25 years of experience; senior officer and advisor for various private and public companies across diverse industries, including energy, mining, and technology.

FOXCONN

ASUS



TESLA



BC Hydro



# Board & Advisors

Batteries, Utilities, Energy, Entrepreneurs



**Benjamin Chen**

*Advisor - Product Quality & Safety*

Joined UL in 2000, served as Commercial Engineering Mgr for Energy Storage Systems & eMobility in Greater China, & co-developed the battery repurposing standard, now UL 1974.



**Roman Fontes**

*Advisor - Utilities*

Sr positions with AES, Motorola, & General Dynamics in Large-scale energy infrastructure. Former U.S. Department of Energy for independent power & transmission.



**Cec Primeau**

*Advisor - Finance*

Former Corvus Energy, Finance and entrepreneurial professional working with top Canadian companies in Battery Storage, Food Services & Clean Tech.



**Li Doyle**

*Board - Energy*

Executive roles in energy storage, renewable, energy trading, and energy transition sectors across the US and overseas.



**Adam Morand**

*Board - Manufacturing*

Serial entrepreneur and purpose-driven technologist with decades of experience in product development, eSports, financial systems and energy.



**Paul Dickson**

*Board - Crypto*

Executive management roles with public companies for 30 years, primarily in the technology sector specializing in SaaS platforms within the Crypto, VPN, Web3, Productivity and IoT space.



# Vision

*Building The world's largest decentralized utility network.*

Enhanced Connectivity  
Satellites, IOT, Infrastructure



Energy Trading & Tokenomics



Energy Plug Technologies ALL RIGHTS RESERVED

20 kWh  
Energy Pack

20 kWh  
Energy Pole



Advanced EMS w/  
Blockchain Node

Virtual-Power-Plant (VPP)



Diesel-fed Remote Community  
(Grid-connected & Islanded MG)

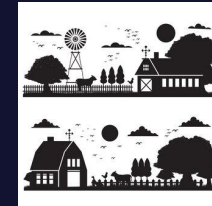

Transportation Electrification



# ENERGY PLUG

Decentralized Energy Technologies

11.24

